

DESCRIPTION

- Winston series kitchen accessory
- 304 Stainless steel construction , polish electrolysis finish

STANDARD

- Comply with Moen standard Q/MESN 4
- Comply with 24HH ASS TEST

WARRANTY

- 1 years limited lifetime warranty against material or manufacturing defects to the original consumer purchaser

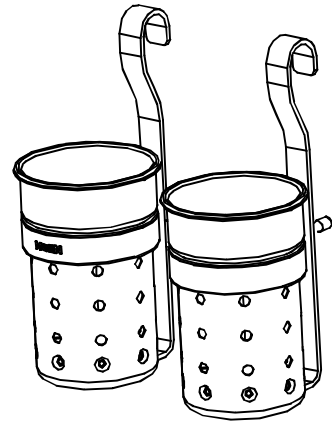

CHOPSTICKS CUP RACK(DOUBLE)

Models: KAC0242

Units : mm

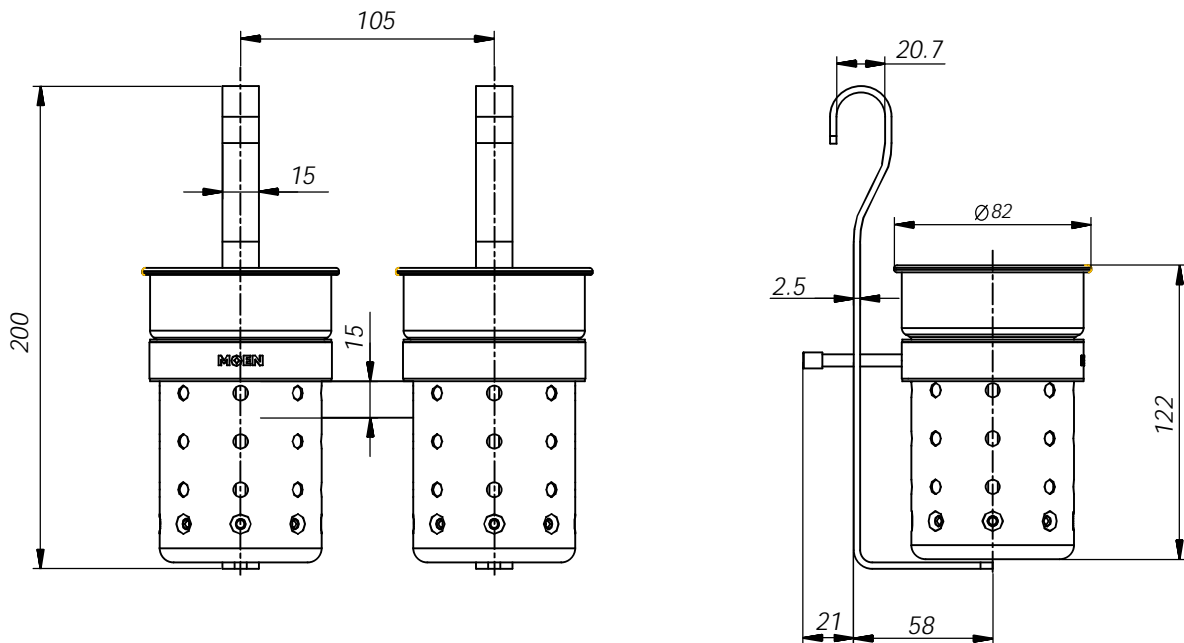

CRITICAL DIMENSION

(DO NOT SCALE)