

DESCRIPTION

- Winston series kitchen accessory
- 304 Stainless steel construction , polish electrolysis finish

STANDARD

- Comply with Moen standard O/MESN 4
- Comply with 24HH ASS TEST

WARRANTY

- 1 years limited lifetime warranty against material or manufacturing defects to the original consumer purchaser

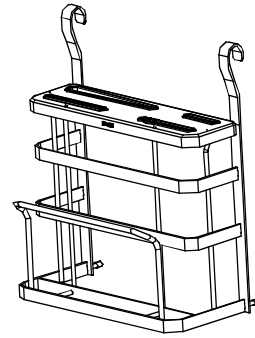

Chop board and knife Rack

Models: KAC0251

Units : mm

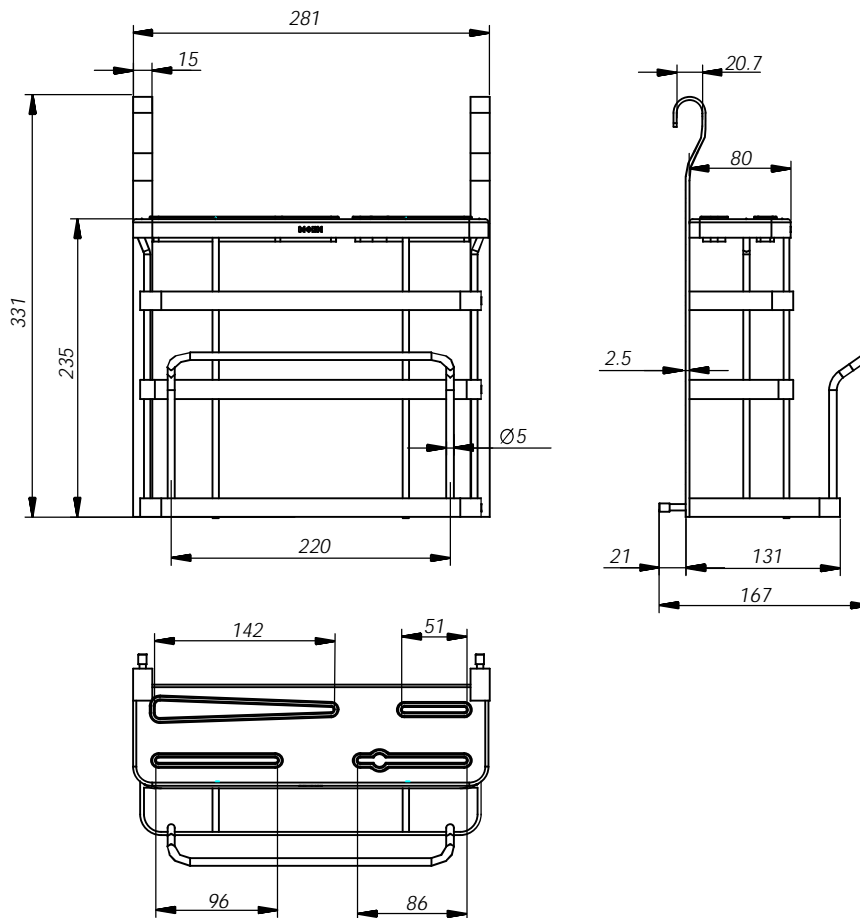

CRITICAL DIMENSION

(DO NOT SCALE)