

REV	ECM NUMBER	CHG BY	PART NUMBER	MAKE FROM	MOEN COLOR	MOEN SPEC	LOGO MARKING
-	700000005811	LIN, JEFF	KAC0411BLK	SEE NOTE 2	ROCK BLACK	AASS 24H, GRADE 10	ES-180

KAC0411BLKSERIES	
DATA SHEET 1 OF 1	
SERIES CHANGE BY	VER
JLIN4	1
SERIES ECM NO.	700000005811

"DO NOT SCALE DRAWING"

"This document is the exclusive property of Moen Incorporated, and may not be reproduced, nor may the information contained therein or derivable therefrom be used in any manner except by written permission of Moen Incorporated. The proprietary rights to the aforesaid information, both of a patentable and unpatentable nature, are expressly reserved to Moen Incorporated."

DISH RACK

MOEN[®]

MOEN INCORPORATED, 25300 AL MOEN DRIVE
NORTH OLMSTED, OH 44070, U S A

DRAW SIZE	DRAWING NO.
3	KAC0411BLKSERIES

This document is UNCONTROLLED once printed

1.1 THE MAKE FROMS LISTED IN THE TABLE ABOVE REPRESENT THE TYPICAL METHOD OF MANUFACTURE AT MOEN INCORPORATED. A FINISH MAY ALSO BE PROCESSED STARTING FROM ITS RAW MATERIAL FORM. THIS DOES NOT PERMIT THE USE OF ALTERNATE RAW MATERIALS IF THEY ARE NOT EXPLICITLY LISTED ON MOEN DRAWINGS.

1.2 PARTS SHALL MEET APPROVED COSMETIC STANDARDS WHEN INSPECTED PER MOEN COSMETIC STANDARD PROCEDURE 02-05.

1.3 FINAL PART APPEARANCE PER MOEN COLOR DRAWING 104335.

1.4 UNLESS OTHERWISE SPECIFIED, ALL MOEN DRAWING REQUIREMENTS/DEFINITIONS MUST CONFORM TO MOEN ENGINEERING STANDARD ES-195

1.5 UNLESS OTHERWISE SPECIFIED IN THE PPAP DOC QN, BOTH THE VENDOR AND PARTS/ASSEMBLIES MUST CONFORM TO THE REQUIREMENTS OF THE FORTUNE BRANDS GLOBAL PLUMBING GROUP PPAP MANUAL, LATEST REVISION

1.6 UNSPECIFIED PART GEOMETRY PER MOEN 3D PART FILE AND MUST CONFORM WITHIN A BILATERAL PROFILE TOLERANCE OF $\frac{0.050}{A|B|C}$

1.7 UNLESS OTHERWISE SPECIFIED, ALL DIMENSIONS APPLY TO ALL FINISHES

1.8 TOLERANCED DIMENSIONS REFERENCED BY THIS NOTE APPLY TO CHROME AND CHROME NM FINISHES ONLY. ASSOCIATED MIN OR MAX DIMENSION APPLIES TO ALL OTHER FINISHES

1.9 APPLY TEXTURE TO GEOMETRY AS SHOWN BY TEXTURE ARROWS. APPLIES TO TEXTURED FINISHES

NOTE:

1. MATERIAL: SEE THE TABLE LIST.
2. UNSPECIFIED TOLERANCE OF DIMENSION AS GB/T1804-2000, GRADE IT14
3. UNLESS OTHERWISE SPECIFIED ,ALL THE SHARP EDGES MUST BE FILLETED IN RADII 0.5-1MM
4. NO MELTING LINE ALLOWANCE IN THE APPEARANCE SURFACE
5. PRODUCT MUST COMPLY WITH MOEN Q/ MESN 4 REQUIREMENT

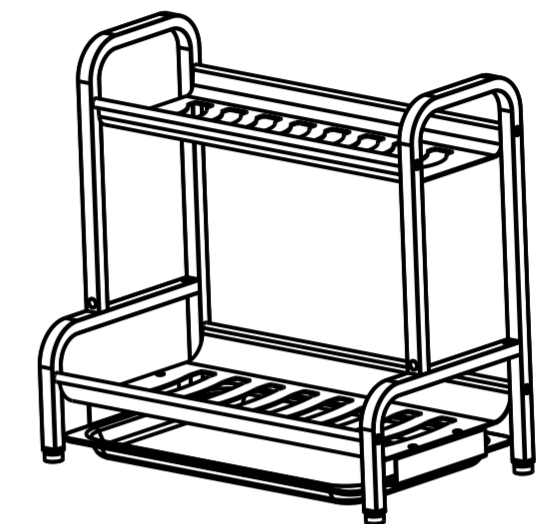

□□ 0.150

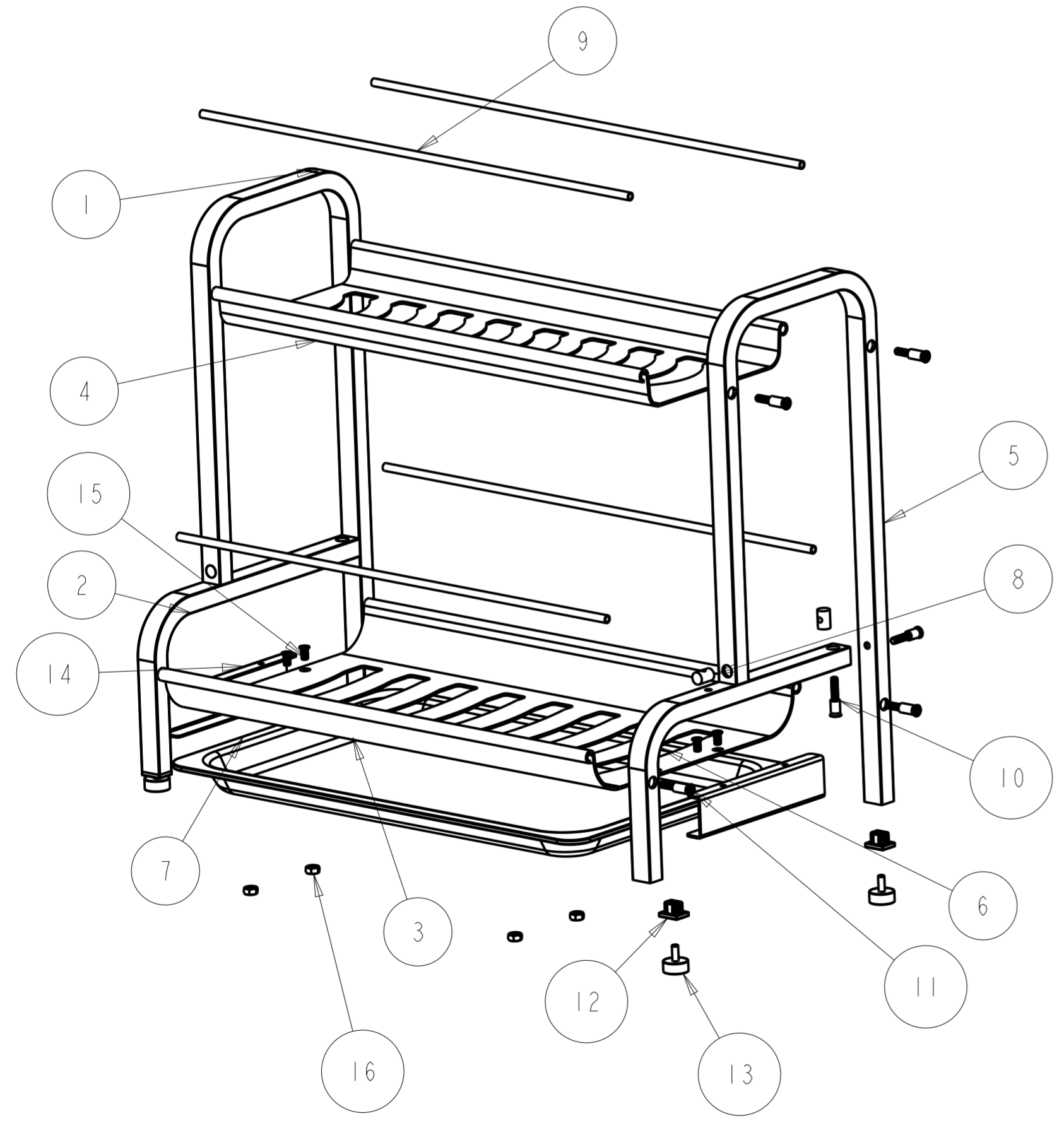

16	YLM0400	SHELF	4	ALUMINUM	SEE TABLE
15	YCT0408_02	SCREW	4	SUS304	SEE TABLE
14	PK45905	SHELF	2	ALUMINUM	SEE TABLE
13	YK409AA	SCREW	4		
12	YK409AB	COVER	4	ABS	SEE TABLE
11	YK45972	SCREW	8	SUS304	SEE TABLE
10	YK45970	SCREW	4	SUS304	SEE TABLE
9	YK45906	rod	4	ALUMINUM	SEE TABLE
8	YK45971	SCREW	4	ALUMINUM	SEE TABLE
7	YK409PP	SINK	1	PP	SEE TABLE
6	PK45912	STENTS	1	ALUMINUM	SEE TABLE
5	YK45911	STENTS	1	ALUMINUM	SEE TABLE
4	PK45903	SHELF	1	ALUMINUM	SEE TABLE
3	PK45904	SHELF	1	ALUMINUM	SEE TABLE
2	YK45902	STENTS	1	ALUMINUM	SEE TABLE
1	YK45901	STENTS	1	ALUMINUM	SEE TABLE
ITEM	PN	PART NAME	QTY/SET	MATERIAL	FINISH

"DO NOT SCALE DRAWING"
UNLESS OTHERWISE SPECIFIED
INTERPRET DRAWING PER ASME Y14.5-2009

VALID ECM NUMBER	700000005811
EST.WEIGHT-gr[lb]	0.00010.000
EST.VOLUME-cm ³ [in ³]	0.00010.000
EST.SURF-AREA-mm ² [in ²]	0.00010.000
EST.COSM SURF AREA in ²	
PROJECT NUMBER	&project_number

"This document is the exclusive property of Moen Incorporated, and may not be reproduced, nor may the information contained therein or derivable therefrom be used in any manner except by written permission of Moen Incorporated. The proprietary rights to the aforesaid information, both of a patentable and unpatentable nature, are expressly reserved to Moen Incorporated."

DISH RACK

MOEN
MOEN GUANGZHOU FAUCET CO., LTD
SHANGYUANGANG SHAHE TIANHE GUANGZHOU P. R. CHINA

UNITS METRIC [ENGLISH]	DIMENSION CLASSIFICATION
DRAWN BY JLIN	
APPROVED REY LIU	
DATE 12-Mar-20	DRAW SIZE A2
SCALE 0.330	DRAWING NO. KAC0411BLKSERIES

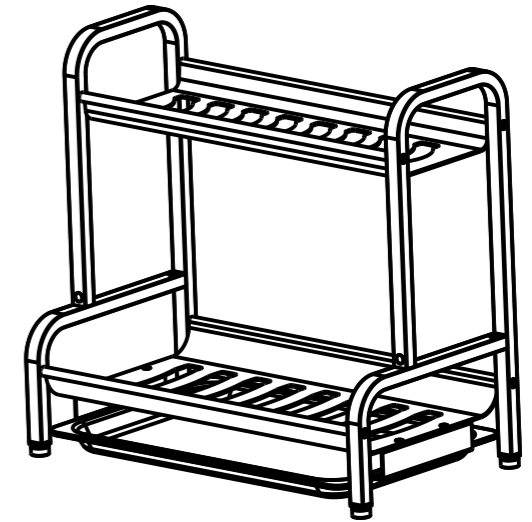
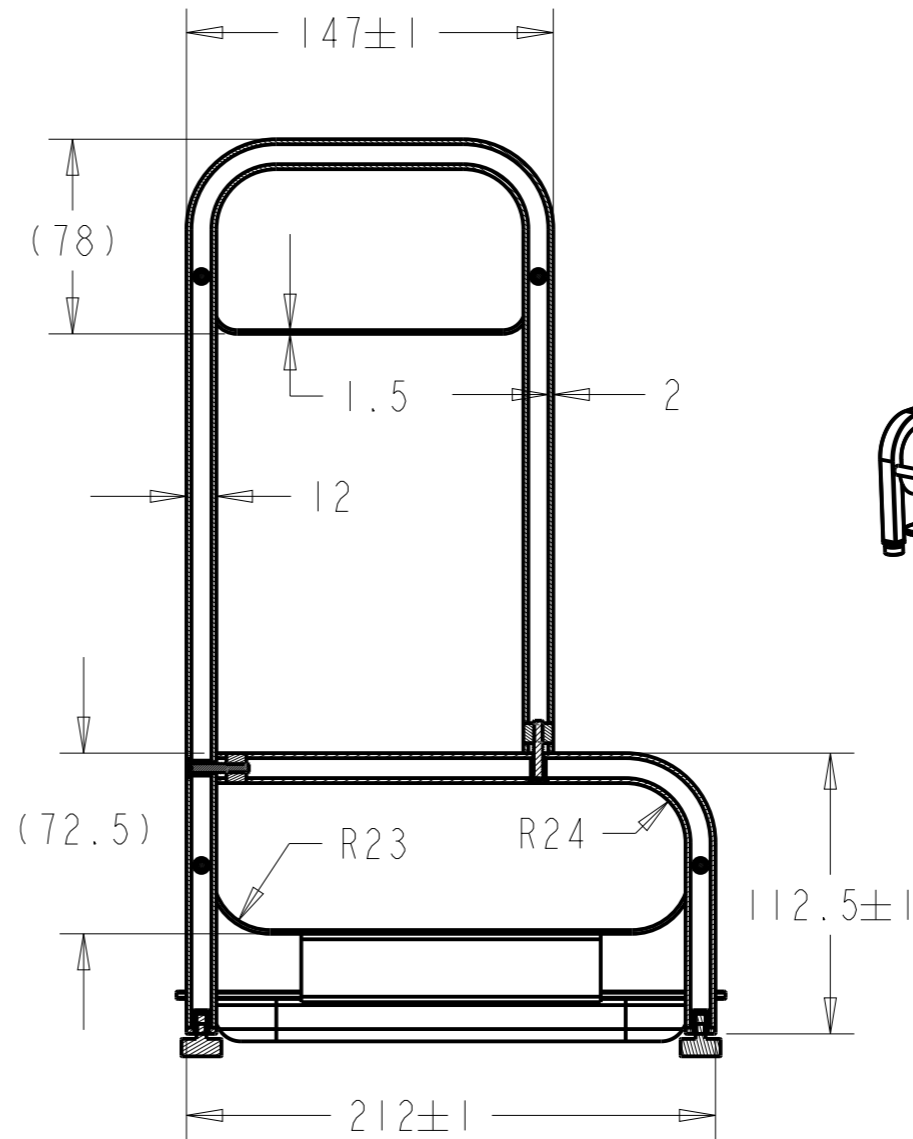
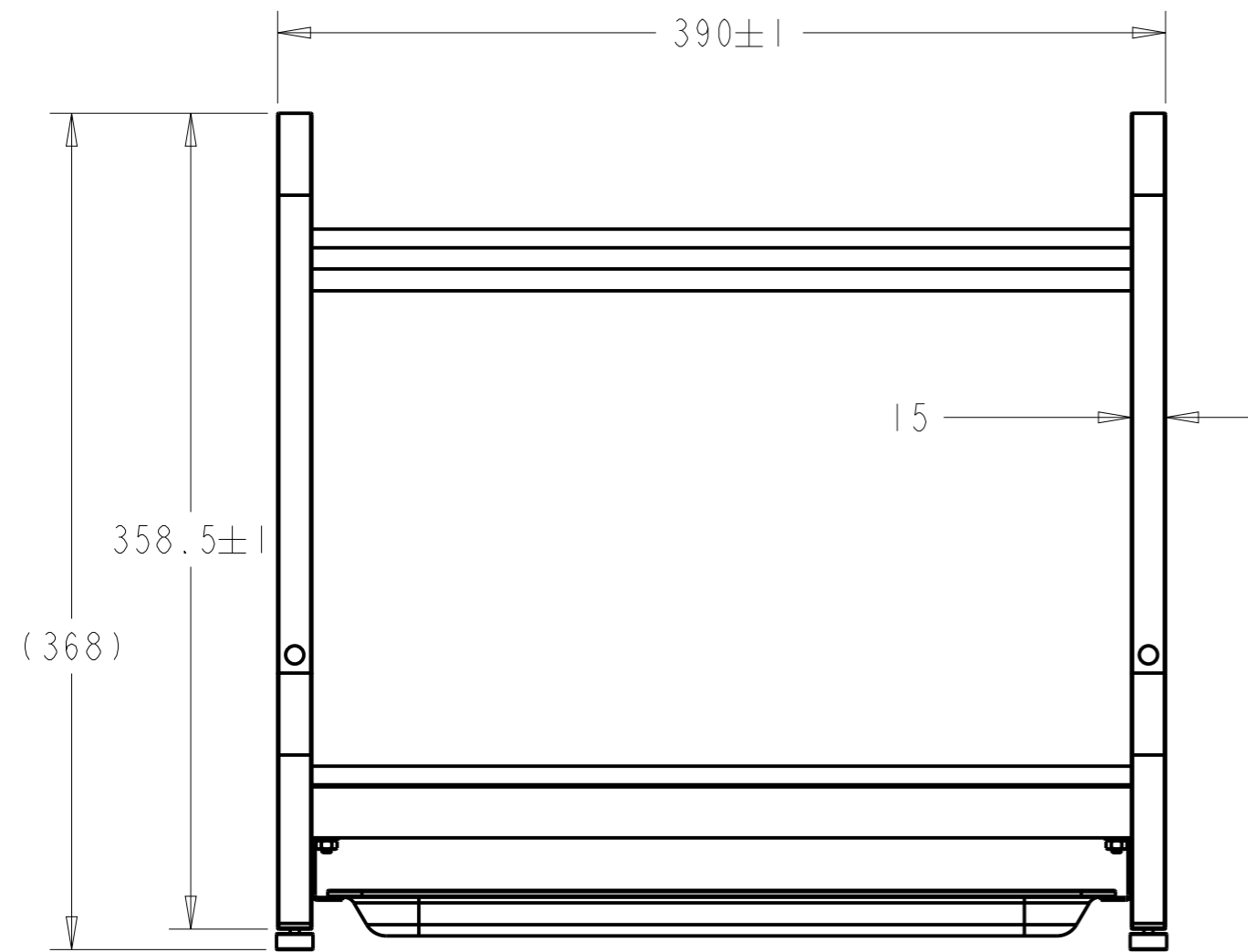

□□ 0.150

□□ XSEC0003-XSEC0003

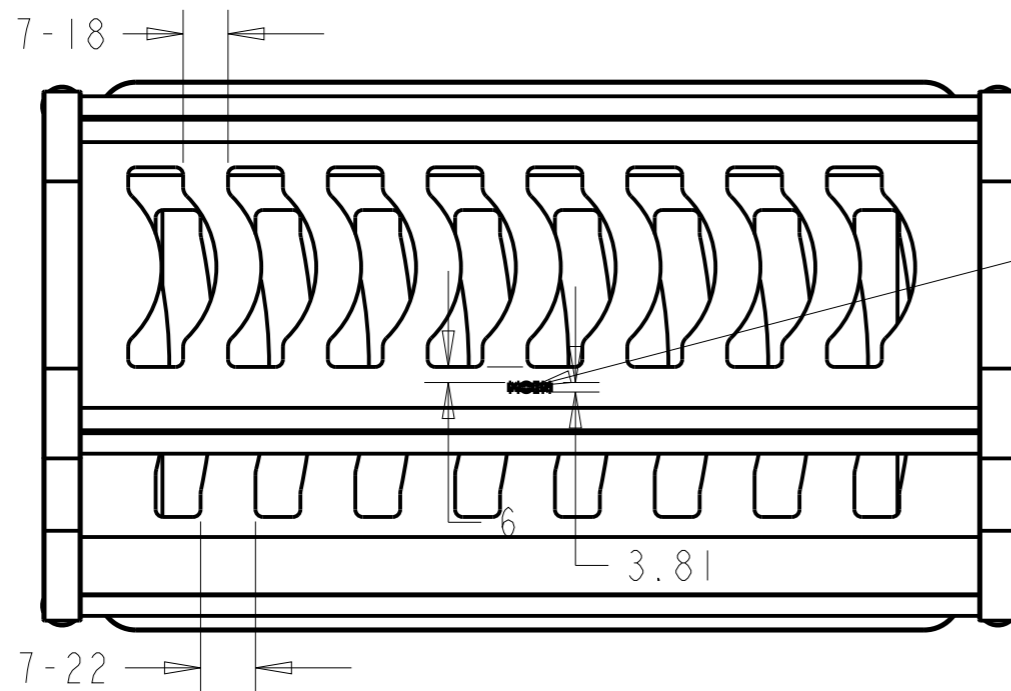

MOEN LOGO PER L-124400-150. SEE MOEN SPECIFICATION ES-180 FOR DIMENSION, LOCATION, AND MARKING REQUIREMENTS

"DO NOT SCALE DRAWING"	
UNLESS OTHERWISE SPECIFIED INTERPRET DRAWING PER ASME Y14.5-2009	
VALID ECM NUMBER	70000005811
EST.WEIGHT-gr[lb]	0.000[0.000]
EST.VOLUME-cm ³ [in ³]	0.000[0.000]
EST.SURF-AREA-mm ² [in ²]	0.000[0.000]
EST.COSM SURF AREA in ²	
PROJECT NUMBER	&project_number

"This document is the exclusive property of Moen Incorporated, and may not be reproduced, nor may the information contained therein or derivable therefrom be used in any manner except by written permission of Moen Incorporated. The proprietary rights to the aforesaid information, both of a patentable and unpatentable nature, are expressly reserved to Moen Incorporated."

DISH RACK			
UNITS METRIC [ENGLISH]	DIMENSION CLASSIFICATION	MOEN MOEN GUANGZHOU FAUCET CO. LTD SHANGYUANGANG SHAHE TIANHE GUANGZHOU P. R. CHINA	APPROVED REY LIU
	KEY CHARACTERISTIC STATISTICAL TOLERANCE		
DRAWN BY JLIN		DRAWING NO. KAC0411BLKSERIES	
DATE 12-Mar-20	DRAW SIZE A3	SCALE 0.330	

