

| REV | ECM NUMBER | CHG BY | PART NUMBER | MAKE FROM | MOEN COLOR | MOEN SPEC | LOGO MARKING |
|-----|--------------|-----------|-------------|------------|------------|-----------------------|--------------|
| - | 700000005763 | LIN, JEFF | KAC0481BLK | SEE NOTE 2 | ROCK BLACK | AASS 24H, GRADE 10 | ES-180 |

| | |
|-------------------|--------------|
| KAC0481BLKSERIES | |
| DATA SHEET 1 OF 1 | |
| SERIES CHANGE BY | VER |
| JLIN4 | 1 |
| SERIES ECM NO. | 700000005763 |

"DO NOT SCALE DRAWING"

"This document is the exclusive property of Moen Incorporated, and may not be reproduced, nor may the information contained therein or derivable therefrom be used in any manner except by written permission of Moen Incorporated. The proprietary rights to the aforesaid information, both of a patentable and unpatentable nature, are expressly reserved to Moen Incorporated."

HOOKS SET



MOEN INCORPORATED, 25300 AL MOEN DRIVE
NORTH OLMSTED, OH 44070, U S A

| | |
|-----------|------------------|
| DRAW SIZE | DRAWING NO. |
| 3 | KAC0481BLKSERIES |

This document is UNCONTROLLED once printed

1.1 THE MAKE FROMS LISTED IN THE TABLE ABOVE REPRESENT THE TYPICAL METHOD OF MANUFACTURE AT MOEN INCORPORATED. A FINISH MAY ALSO BE PROCESSED STARTING FROM ITS RAW MATERIAL FORM. THIS DOES NOT PERMIT THE USE OF ALTERNATE RAW MATERIALS IF THEY ARE NOT EXPLICITLY LISTED ON MOEN DRAWINGS.
 1.2 PARTS SHALL MEET APPROVED COSMETIC STANDARDS WHEN INSPECTED PER MOEN COSMETIC STANDARD PROCEDURE 02-05.
 1.3 FINAL PART APPEARANCE PER MOEN COLOR DRAWING 104335.
 1.4 UNLESS OTHERWISE SPECIFIED, ALL MOEN DRAWING REQUIREMENTS/DEFINITIONS MUST CONFORM TO MOEN ENGINEERING STANDARD ES-195
 1.5 UNLESS OTHERWISE SPECIFIED IN THE PPAP DOC QN, BOTH THE VENDOR AND PARTS/ASSEMBLIES MUST CONFORM TO THE REQUIREMENTS OF THE FORTUNE BRANDS GLOBAL PLUMBING GROUP PPAP MANUAL, LATEST REVISION
 1.6 UNSPECIFIED PART GEOMETRY PER MOEN 3D PART FILE AND MUST CONFORM WITHIN A BILATERAL PROFILE TOLERANCE OF $\frac{0.050}{A|B|C}$
 1.7 UNLESS OTHERWISE SPECIFIED, ALL DIMENSIONS APPLY TO ALL FINISHES
 1.8 TOLERANCED DIMENSIONS REFERENCED BY THIS NOTE APPLY TO CHROME AND CHROME NM FINISHES ONLY. ASSOCIATED MIN OR MAX DIMENSION APPLIES TO ALL OTHER FINISHES
 1.9 APPLY TEXTURE TO GEOMETRY AS SHOWN BY TEXTURE ARROWS. APPLIES TO TEXTURED FINISHES

NOTE:
 1. MATERIAL: SEE THE TABLE LIST.
 2. UNSPECIFIED TOLERANCE OF DIMENSION AS GB/T1804-2000, GRADE IT14
 3. UNLESS OTHERWISE SPECIFIED, ALL THE SHARP EDGES MUST BE FILLETED IN RADII 0.5-1MM
 4. NO MELTING LINE ALLOWANCE IN THE APPEARANCE SURFACE
 5. PRODUCT MUST COMPLY WITH MOEN Q/ MESN 4 REQUIREMENT

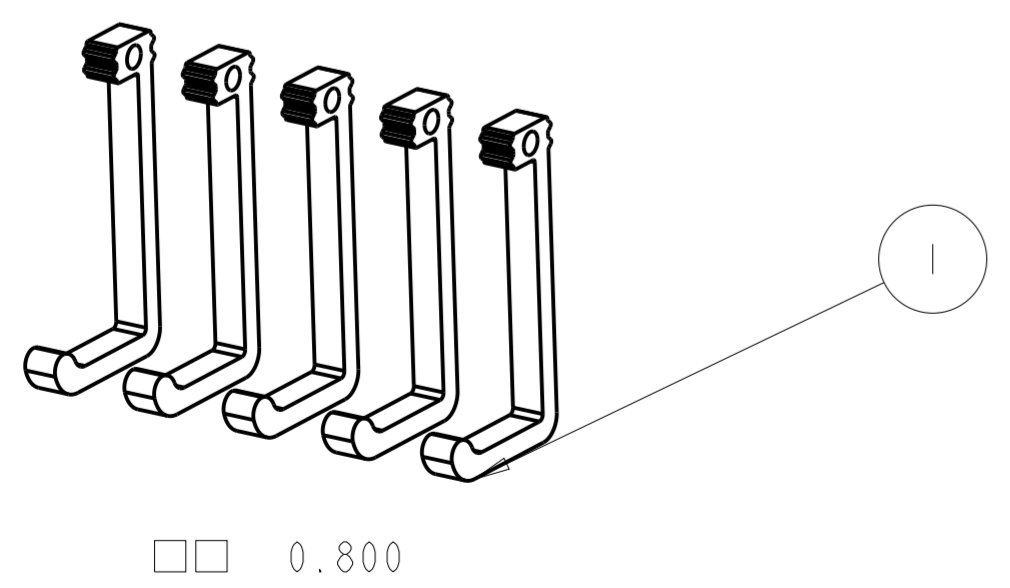
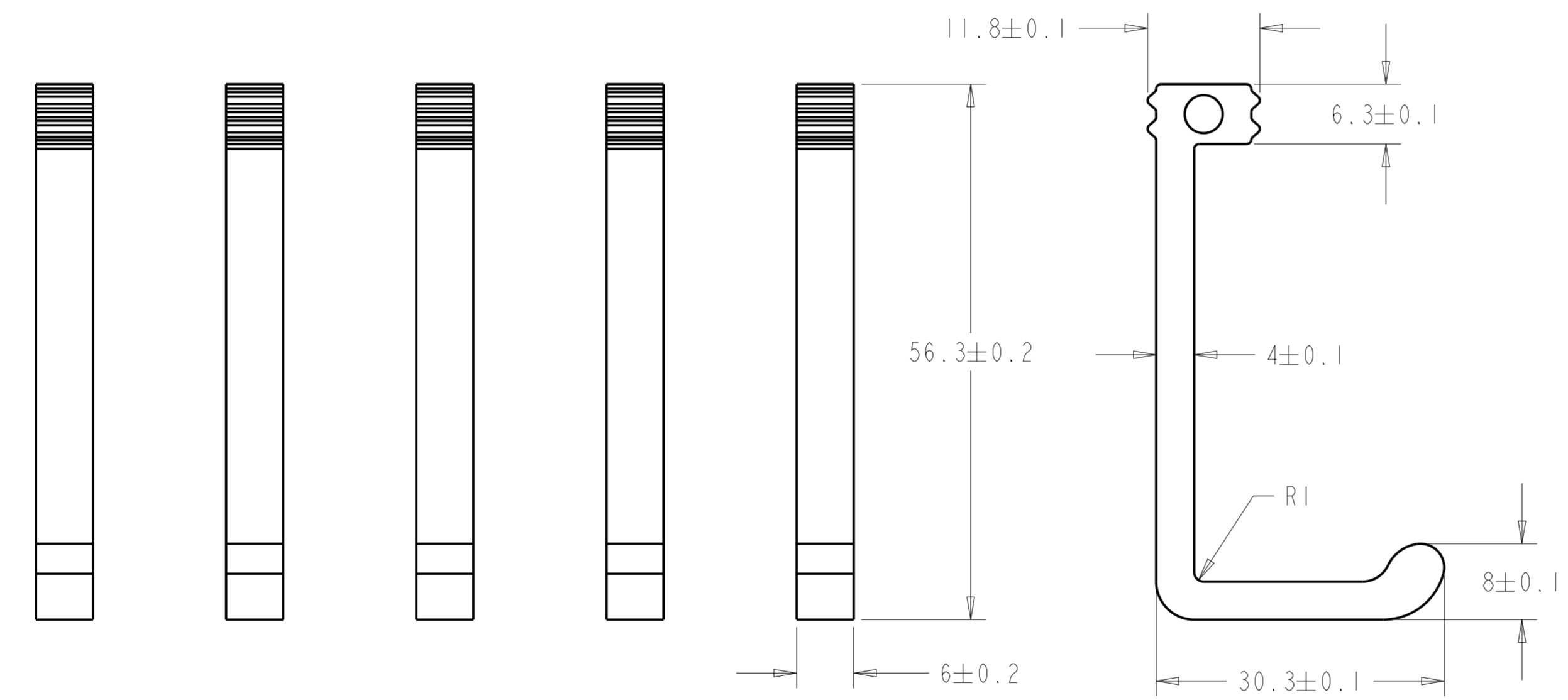

| | | | | | |
|------|---------|-----------|---------|----------|-----------|
| 1 | YK46020 | CLRMP | 5 | ALUMINUM | SEE TABLE |
| ITEM | PN | PART NAME | QTY/SET | MATERIAL | FINISH |

"DO NOT SCALE DRAWING"
 UNLESS OTHERWISE SPECIFIED
 INTERPRET DRAWING PER ASME Y14.5-2009

| | |
|--|-----------------|
| VALID ECM NUMBER | 70000005763 |
| EST.WEIGHT-gr[lb] | 0.000[0.000] |
| EST.VOLUME-cm ³ [in ³] | 0.000[0.000] |
| EST.SURF-AREA-mm ² [in ²] | 0.000[0.000] |
| EST.COSM SURF AREA in ² | |
| PROJECT NUMBER | &project_number |

"This document is the exclusive property of Moen Incorporated, and may not be reproduced, nor may the information contained therein or derivable therefrom be used in any manner except by written permission of Moen Incorporated. The proprietary rights to the aforesaid information, both of a patentable and unpatentable nature, are expressly reserved to Moen Incorporated."

HOOKS SET

UNITS METRIC [ENGLISH]

DIMENSION CLASSIFICATION

MOEN
 MOEN GUANGZHOU FAUCET CO., LTD
 SHANGYUANGANG SHAHE TIANHE GUANGZHOU P. R. CHINA

DRAWN BY: APPROVED

DATE: 06-Mar-20
 DRAW SIZE: A2
 SCALE: 2.000
 DRAWING NO.: KAC0481BLKSERIES