

1.1 THE MAKE FROMS LISTED IN THE TABLE ABOVE REPRESENT THE TYPICAL METHOD OF MANUFACTURE AT MOEN INCORPORATED. A FINISH MAY ALSO BE PROCESSED STARTING FROM ITS RAW MATERIAL FORM. THIS DOES NOT PERMIT THE USE OF ALTERNATE RAW MATERIALS IF THEY ARE NOT EXPLICITLY LISTED ON MOEN DRAWINGS.

1.2 PARTS SHALL MEET APPROVED COSMETIC STANDARDS WHEN INSPECTED PER MOEN COSMETIC STANDARD PROCEDURE 02-05.

1.3 FINAL PART APPEARANCE PER MOEN COLOR DRAWING 104335.

1.4 UNLESS OTHERWISE SPECIFIED, ALL MOEN DRAWING REQUIREMENTS/DEFINITIONS MUST CONFORM TO MOEN ENGINEERING STANDARD ES-195

1.5 UNLESS OTHERWISE SPECIFIED IN THE PPAP DOC QN, BOTH THE VENDOR AND PARTS/ASSEMBLIES MUST CONFORM TO THE REQUIREMENTS OF THE FORTUNE BRANDS GLOBAL PLUMBING GROUP PPAP MANUAL, LATEST REVISION

1.6 UNSPECIFIED PART GEOMETRY PER MOEN 3D PART FILE AND MUST CONFORM WITHIN A BILATERAL PROFILE TOLERANCE OF $\frac{0.050}{A|B|C}$

1.7 UNLESS OTHERWISE SPECIFIED, ALL DIMENSIONS APPLY TO ALL FINISHES

1.8 TOLERANCED DIMENSIONS REFERENCED BY THIS NOTE APPLY TO CHROME AND CHROME NM FINISHES ONLY. ASSOCIATED MIN OR MAX DIMENSION APPLIES TO ALL OTHER FINISHES

1.9 APPLY TEXTURE TO GEOMETRY AS SHOWN BY TEXTURE ARROWS. APPLIES TO TEXTURED FINISHES

NOTE:

1. MATERIAL: SEE THE TABLE LIST.
2. UNSPECIFIED TOLERANCE OF DIMENSION AS GB/T1804-2000, GRADE IT14
3. UNLESS OTHERWISE SPECIFIED ,ALL THE SHARP EDGES MUST BE FILLETED IN RADII 0.5-1MM
4. NO MELTING LINE ALLOWANCE IN THE APPEARANCE SURFACE
5. PRODUCT MUST COMPLY WITH MOEN Q/ MESN 4 REQUIREMENT

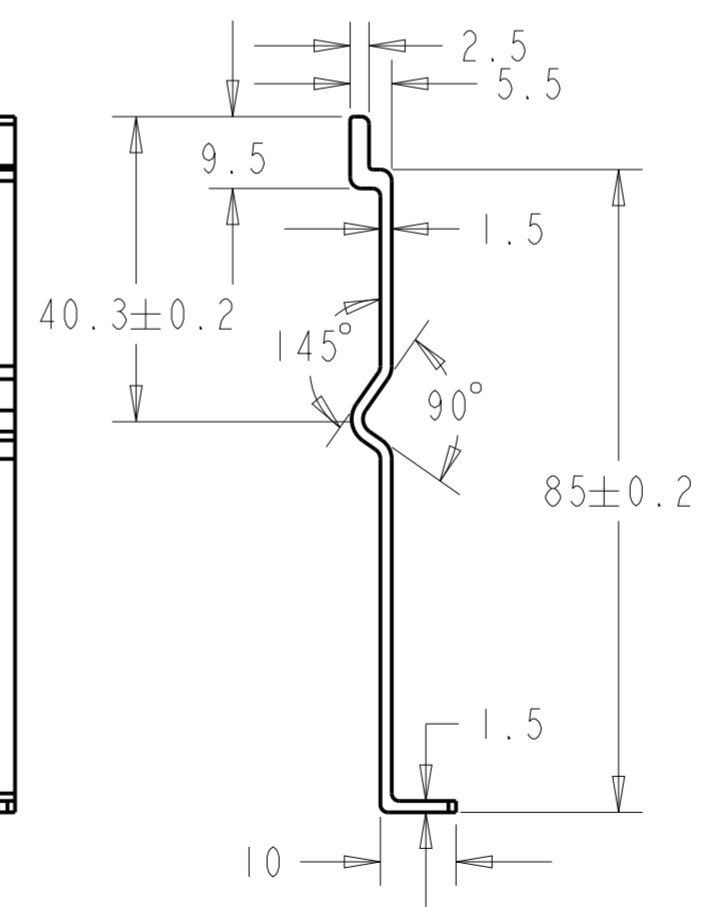
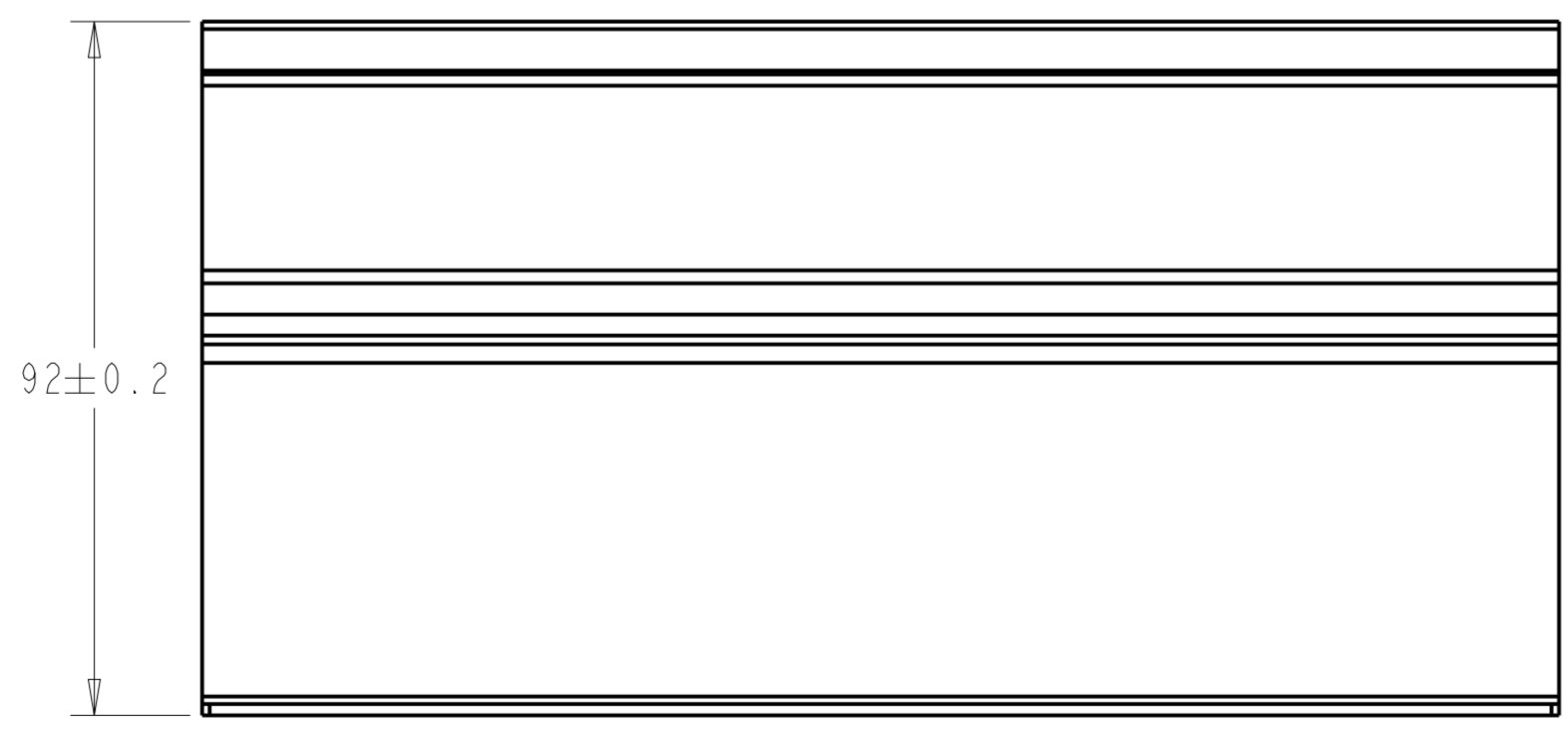
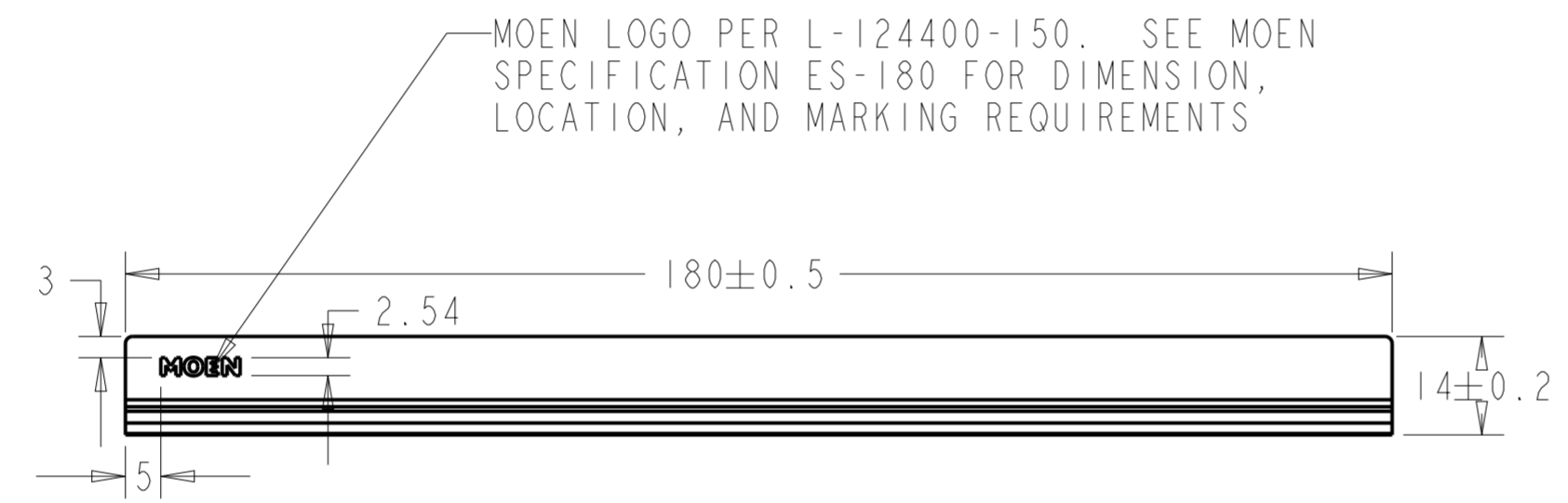
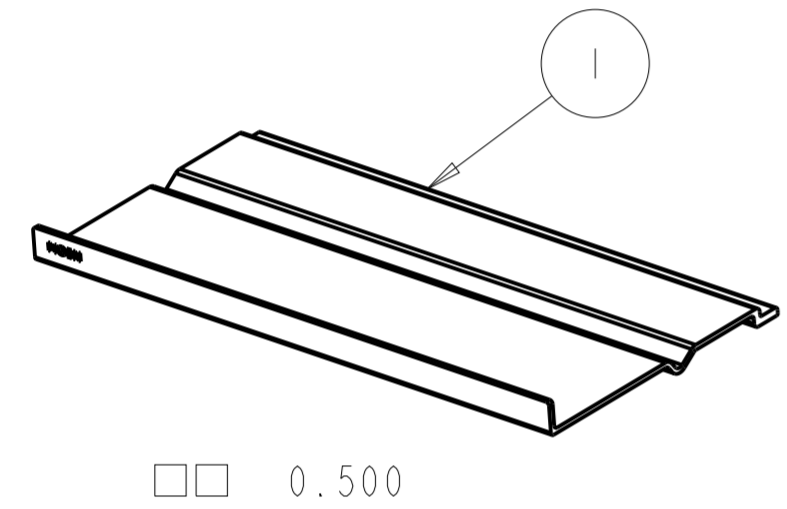

MOEN LOGO PER L-124400-150. SEE MOEN SPECIFICATION ES-180 FOR DIMENSION, LOCATION, AND MARKING REQUIREMENTS

ITEM	YK45330	RPLATE	ALUMINUM	SEE TABLE
	PN	PART NAME	QTY/SET	MATERIAL FINISH

"DO NOT SCALE DRAWING"

UNLESS OTHERWISE SPECIFIED INTERPRET DRAWING PER ASME Y14.5-2009

VALID ECM NUMBER	700000005818
EST.WEIGHT-gr[lb]	0.000[0.000]
EST.VOLUME-cm ³ [in ³]	0.000[0.000]
EST.SURF-AREA-mm ² [in ²]	0.000[0.000]
EST.COSM SURF AREA in ²	
PROJECT NUMBER	&project_number

"This document is the exclusive property of Moen Incorporated, and may not be reproduced, nor may the information contained therein or derivable therefrom be used in any manner except by written permission of Moen Incorporated. The proprietary rights to the aforesaid information, both of a patentable and unpatentable nature, are expressly reserved to Moen Incorporated."

SHELF BAR

UNITS METRIC [ENGLISH]

DIMENSION CLASSIFICATION

MOEN

MOEN GUANGZHOU FAUCET CO., LTD
SHANGYUANGANG SHAHE TIANHE GUANGZHOU P. R. CHINA

DRAWN BY: JEFF LIN

APPROVED: RAY LIU

DATE: 06-Mar-20

DRAW SIZE: A2

SCALE: 1.000

DRAWING NO.: KAC0491BLKSERIES