

### Disposal Description

- EX Series is built for powerful performance and dependable functionality
- Remo swith control , do not need to machine a hole on the deck or wall for installation
- 1/2 Horsepower Motor has powerful grinding capabilities for everyday kitchen scraps
- Permanent magnet motor technology designed to help reduce jamming
- Universal Xpress Mount™ fits all Moen and most existing 3-bolt mounting assemblies
- Easy Open Dishwasher Inlet: no tools required
- Safe for use with properly sized septic systems
- Pre-installed power cord - a savings over models where cord must be purchased separately, cord easily removes for optional hardwiring
- SoundSHIELD™ sound deadening insulation
- Compact design frees up space under the sink
- Manual Reset Button
- Garbage disposals reduce waste sent to landfills making it an eco-friendly option for your home
- Continuous feed with stainless steel turntable & galvanized grind components

### Included Components

- EX75MCL Disposal Unit with Universal Xpress Mount™
- Remo swith control and socket
- Pre-installed Power Cord, Hardwire Capable
- Removable Splash Guard
- Drain Stopper and Stainless Steel Sink Flange
- Drain Elbow and Mounting Assembly

### Compliance

- Disposal comply with GB4706.1-2005 and GB4706.49-2008
- Remo swith contol comply with GB1002-2008 ,GB2099.1-2008,GB2099.3-2015

### Warranty & Assurance

- Motor : 5 year limited warranty with in-home service
- Remo swith control : 3 year limited warranty
- Safe for use with properly sized septic systems



**Model: EX75MCL**

### Critical Dimensions

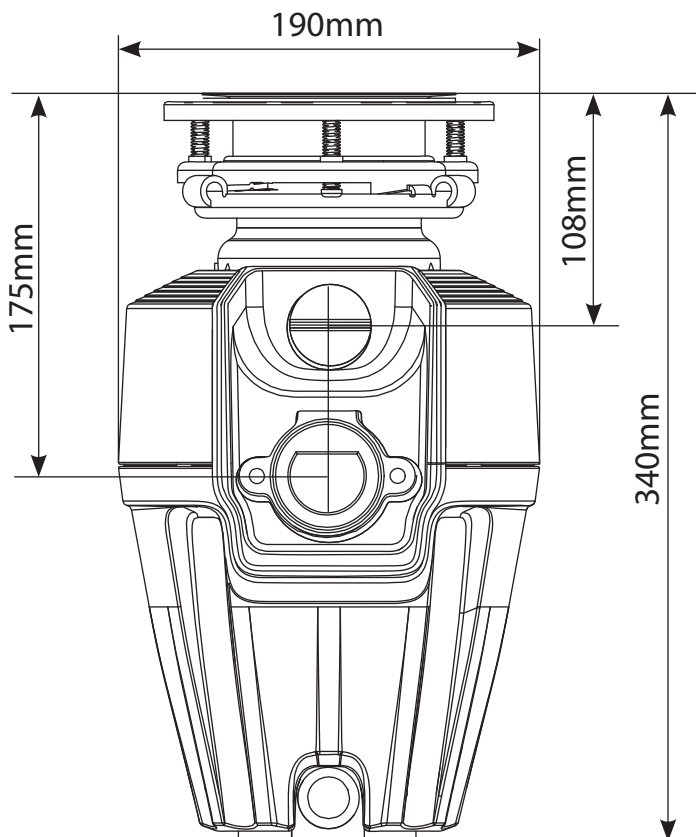

Specification Detail	
Horsepower	1/2 HP
Feed Type	Continuous
On/Off Controls	Remo Switch
Motor Type	Permanent Magnet Motor
RPM (Revolutions Per Minute)	2600
Weight	5.9 kg
Volts/Watt	220/520
Hz/Amps	50/3.0
Drain Connection Size	1 1/2" / 38mm
Dishwasher Connection Size	7/8" / 22mm
Maximum Sink Thickness	1/2" / 13mm
Sink Drain Flange Finish	Stainless Steel
Grind Component Material	Stainless Steel
Grind Chamber Material	Corrosion Proof Glass Filled Polyester and Nylon