

DESCRIPTION

- Plastic and stainless steel construction
- G 2 connection

STANDARD

- Comply with QB/T 4013-2010 and JC 932-2013
- Comply with 24H ASS TEST

WARRANTY

- 1 years limited warranty against material or manufacturing defects to the original consumer purchaser

Units : mm

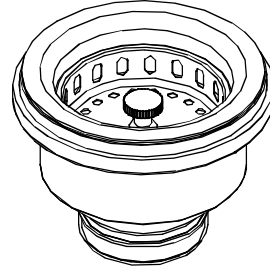

Drainager

Models: SB35

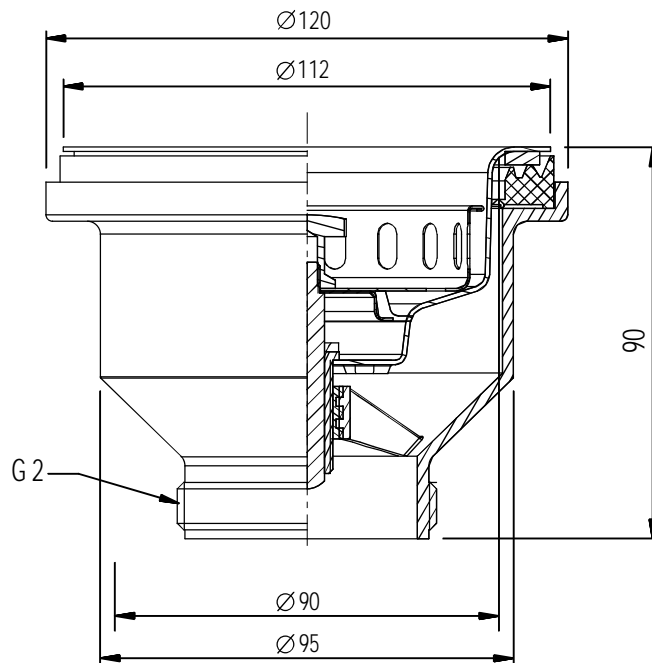

CRITICAL DIMENSION

(DO NOT SCALE)