

DESCRIPTION

- Metal construction with Chrome plated finish

STANDARD

- Comply with QB1560-2006
- Product finish AASS 24H grade 10.

WARRANTY

- 5 years limited warranty except artificial damage and chemicals erosion

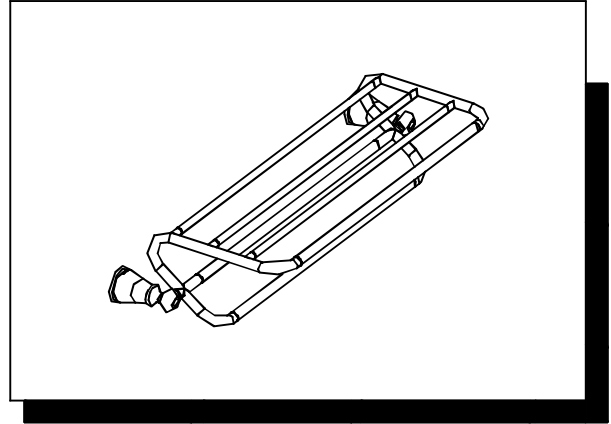

NOTE: ALL DIMENSIONS ARE MM.

DOUBLE TOWEL SHELF
Models: ACC2101 SERIES

